

# OSBORNE HEAT PAD CONTROL

Model F920D



## INSTALLATION AND USE INSTRUCTIONS

### LOCATION

The sensor of the Model F920D control must be in the same general area as the heat pads. The sensor must be subjected to the same air temperature as the heat pads, *but should not be installed directly on any particular heat pad or its surface.* A good location for the sensor is about 12-in above floor level, slightly withdrawn inside an open-ended protective conduit attached to a wall or post. **DO NOT** locate the sensor directly on a heat pad or close to space heaters, fans or doorways.

#### CAUTION:

**The sensor and sensor cable must be protected from damage by animals or man.**

The control enclosure must be mounted in a **vertical position only** (i.e., control knob in upper position.) An arrow inside the case indicates the correct position. The control enclosure must be installed with care to prevent stressing and breakage of the case. Use watertight conduit fittings and sealing compound to complete the installation according to electrical code requirements for watertight installations.

### ELECTRICAL

Only a qualified electrician should install the F920D control according to applicable electric codes using the INSTALLATION DIAGRAM as a guide. The F920D must be connected in series with two fused (20 amp max) safety switches which permit convenient, quick power disconnection for wash-down and cleaning. The "LOAD" outputs of the F920D control are connected to two distribution loops of standard outlets (see Diagram) that supply electricity to the Stanfield Heat Pads. The maximum heat pad load for the F920D is 20 amps at 120 volts or 2,400 watts per circuit. The load for each circuit can be determined by adding the wattage rating for all heat pads plugged into the outlets for each circuit. **DO NOT** attempt F920D repair without instructions from the factory; improper regulation or damage not covered by warranty may result.

#### WARNING

**Beware of shock hazard. Always disconnect electrical power before installing or removing the F920D from the circuit and during washing operations. Do not assume that power is disconnected when the green "POWER" light is OFF. The lamp may have failed but power may still be present.**

If power is connected to the F920D and the green "POWER" light is not illuminated, check the 1/2 AMP fuse located inside the control enclosure. To check the fuse, first disconnect power to the control. Loosen the six screws that hold the face plate of the F920D to the back of the control enclosure. Be careful not to over extend the cable that connects the face plate to the back of the enclosure. The fuse is located on the relay mounting board in the back of the F920D control. If the fuse is open, replace it with a 1/2 AMP AGC 250V fuse. If the fuse is not open, consult the wiring diagram located on this card and verify that the electrical circuit is securely connected to the proper terminals. When completed, replace the faceplate of the control, being careful not to pinch or disconnect the cable that connects the back of the control to the face plate. Tighten the six screws to ensure that the control remains watertight.

### OPERATION

The Model F920D provides automatic temperature control for Stanfield® Heat Pads. Illumination of the green "POWER" light shows that power is connected to the F920D.

To set the desired operating temperature, adjust the control knob until the heat pads attain desired temperature (mildly warm to the hand). Allow about **15-30** minutes between changes of setting for temperature to reach equilibrium before resetting. The best setting can be determined by close observation of the pigs. When the

#### WARRANTY STATEMENT

Osborne Industries, Inc., warrants its heat pads and controls to be free of defects in material and workmanship under normal use for a period of ONE YEAR from the date of purchase. Power cords and sensor extensions are not included in this warranty. Any heat pad or control which our examination reveals to be defective will be repaired or replaced (at Osborne's option) without charge. Alleged defective products shall be returned to the retailer from whom the product was purchased or to any authorized Osborne dealer. Your name and address must be clearly marked on the product and you must furnish a sales slip indicating the date of purchase if you have not previously completed and returned a warranty registration form. The manufacturer's number (located on the back surface of heat pads or on the circuit board or nameplate of controls) or date of shipment from factory will be used to determine warranty period for products not registered or accompanied by proof of purchase. Osborne Industries, Inc., is not liable for loss or damage resulting from the alteration, misuse, or abuse of the product. **This warranty is limited to repair or replacement of the product and excludes consequential and special damages.**



### WARRANTY REGISTRATION

To protect warranty rights,  
fill in and mail immediately to:  
**OSBORNE INDUSTRIES, INC.**  
P.O. Box 388  
Osborne, KS 67473

Model F920D Serial No \_\_\_\_\_ Date \_\_\_\_\_

Customers Name \_\_\_\_\_

Customer Address \_\_\_\_\_

City \_\_\_\_\_ State \_\_\_\_\_ Zip Code \_\_\_\_\_

E-mail \_\_\_\_\_

Date Purchased \_\_\_\_\_ Where (dealership) \_\_\_\_\_

Dealer Address \_\_\_\_\_

City \_\_\_\_\_ State \_\_\_\_\_ Zip Code \_\_\_\_\_

Yes. Please notify me about promotional offers, new products, and special services from Osborne Industries.

proper setting has been chosen, the pigs spread out over the heat pad and relax with a minimum of restlessness. Once set, the control will automatically change the proportion of **TIME-ON** and **TIME-OFF** to keep the heat pad temperature constant although the building floor-level temperature may vary between 50 and 90 deg. F.

The "HEAT ON" lamp shows when voltage is applied to the heat pads. The higher the control setting or the greater the demand for heat, the greater proportion of time power is applied and the lamp stays on, and vice-versa. The F920D is operating normally if the lamp cycles completely about once every 30 seconds.

If piglets do not use heat pads at all F920D settings, check for:

- Excessive drafts** over the heat pad. Cold drafts will drive the piglets off the heat pad and must be eliminated.
- Heat pad operation.** The heat pad should be gently warm to the hand. Check power cords for breaks and clean plug connectors.
- Sensor location.** Check for special interfering heat or cold condition at sensor. The red "SENSOR FAULT" light indicates an open circuit or fault within the temperature sensor. Disconnect power to the F920D and loosen the six screws that hold the face plate to the mounted enclosure. Be careful not to over extend the cable that connects the face plate to the back of the control enclosure. Check the two sensor connection wires to determine if they are securely connected to the terminals marked "WHITE" and "BLACK". If they are not securely fastened, an open circuit exists. Secure the wires to the terminals. If the wires are securely connected and the sensor fault lamp remains illuminated, replace the sensor

**SERVICE**

**DO NOT** attempt to service the F920D control. Repair of the control can be obtained by returning the complete control, freight prepaid, to Osborne Industries, Inc.

**WARNING**  
**Before opening the cover plate and removing F920D from the heat pad circuits, disconnect electrical power! Failure to disconnect power could result in shock hazard.**

Safely terminate the power wires that were connected to the control after the F920D is disconnected. Carefully pack the control to prevent shipping damage. Include adequate identification and a description of the problem observed with the returning F920D.

**INSTALLATION DIAGRAM**

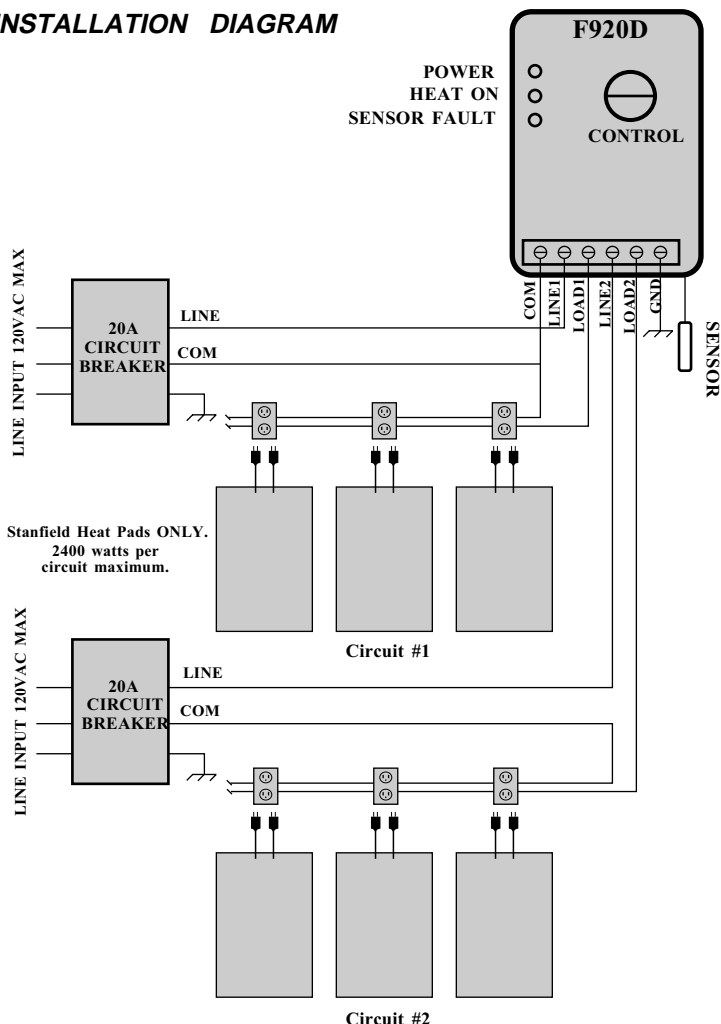

Printed in the U.S.A.

**Return Address**

\_\_\_\_\_

\_\_\_\_\_

\_\_\_\_\_

Place stamp here



**ATTN: CUSTOMER SERVICE DEPARTMENT**